



(19) **United States**

(12) **Patent Application Publication**
Kwon

(10) **Pub. No.: US 2005/0206593 A1**

(43) **Pub. Date: Sep. 22, 2005**

(54) **LIGHT EMITTING DISPLAY, DISPLAY PANEL, AND DRIVING METHOD THEREOF**

Publication Classification

(75) **Inventor: Oh-Kyong Kwon, Seoul (KR)**

(51) **Int. Cl.⁷ G09G 3/30**

(52) **U.S. Cl. 345/76**

Correspondence Address:
CHRISTIE, PARKER & HALE, LLP
PO BOX 7068
PASADENA, CA 91109-7068 (US)

(57) **ABSTRACT**

(73) **Assignee: Samsung SDI Co., Ltd.**

A light emitting display for compensating for the threshold voltage of transistor or mobility and fully charging a data line. A transistor and first through third switches are formed on a pixel circuit of an organic EL display. The transistor supplies a driving current for emitting an organic EL element (OLED). The first switch diode-connects the transistor. A first storage unit stores a first voltage corresponding to a threshold voltage of the transistor. A second switch transmits a data current in response to a select signal. A second storage unit stores a second voltage corresponding to the data current. A third switch transmits the driving current to the OLED. A third voltage determined by coupling of the first and second storage units is applied to a transistor to supply the driving current to the OLED.

(21) **Appl. No.: 11/140,013**

(22) **Filed: May 27, 2005**

Related U.S. Application Data

(63) **Continuation of application No. 10/729,256, filed on Dec. 4, 2003, now Pat. No. 6,919,871.**

(30) **Foreign Application Priority Data**

Apr. 1, 2003 (KR) 2003-0020432

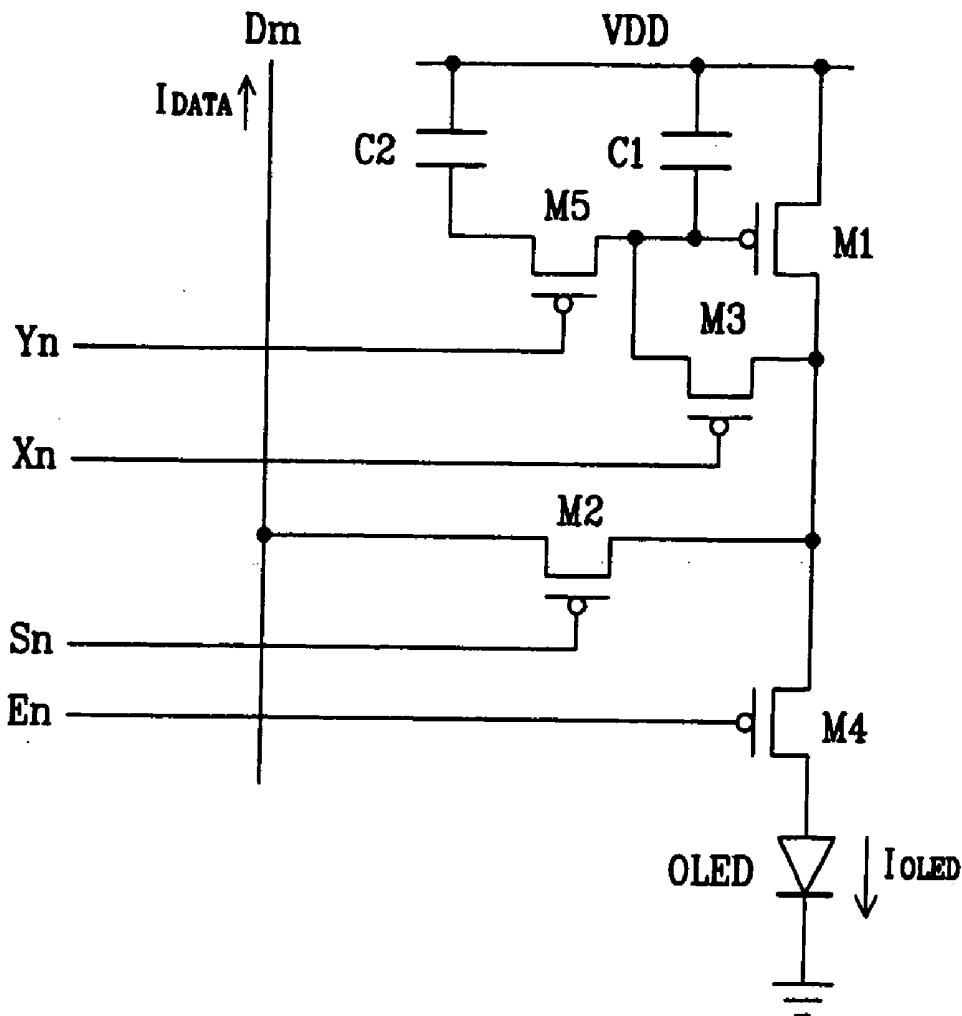

FIG.1

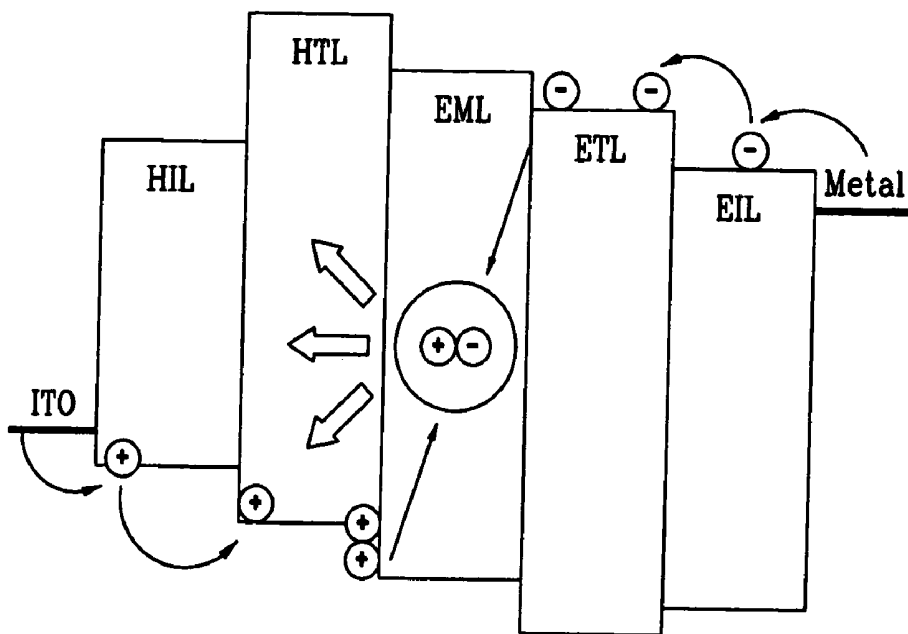

FIG.2

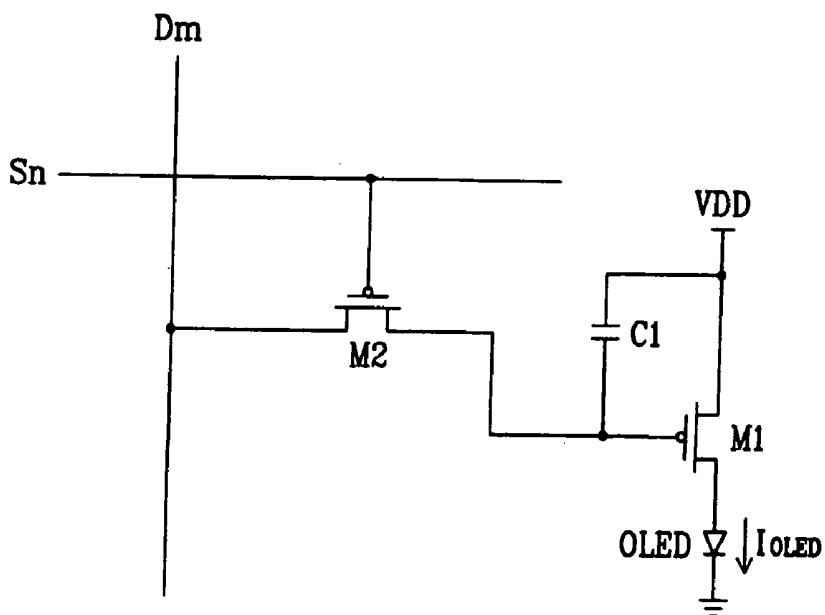

FIG.3

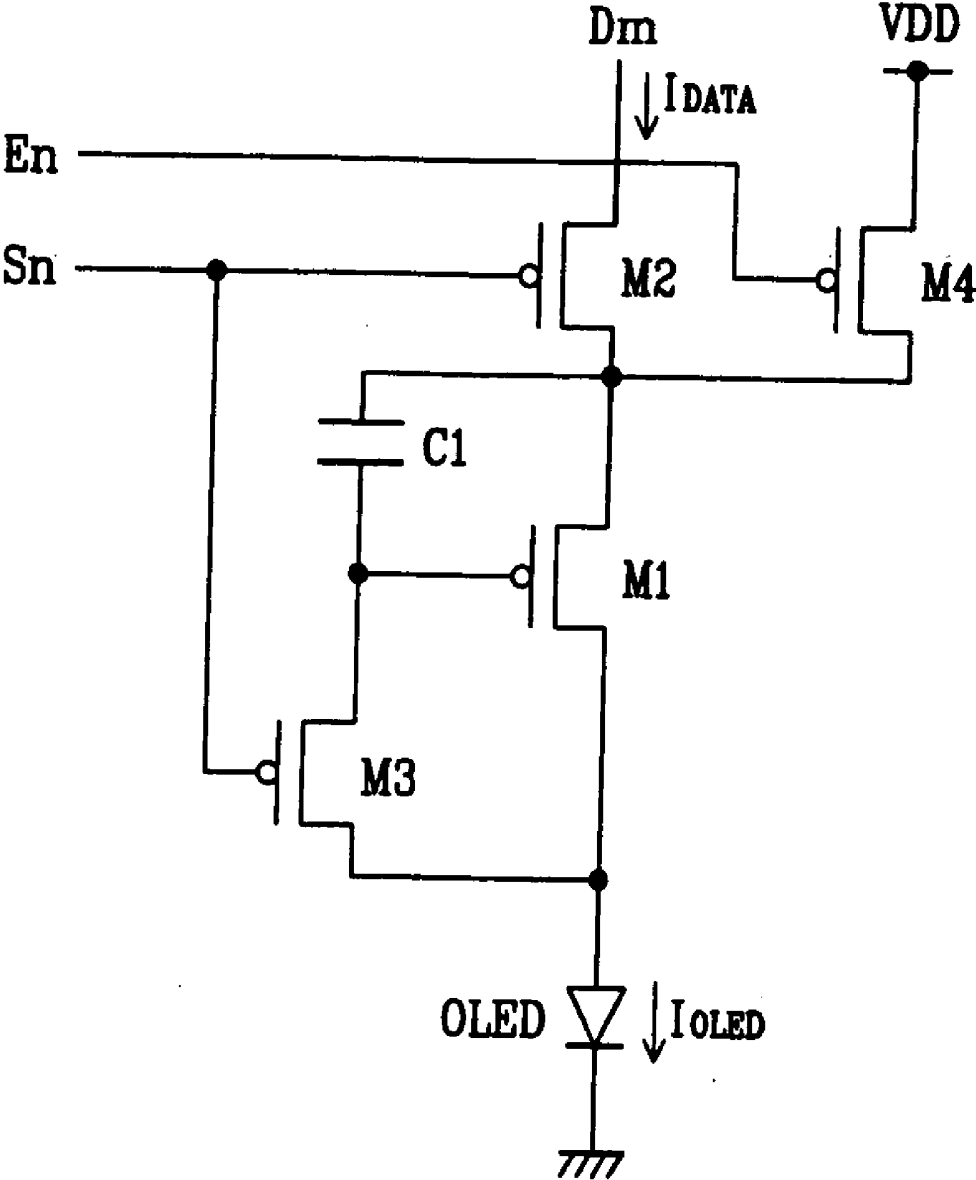

FIG. 4

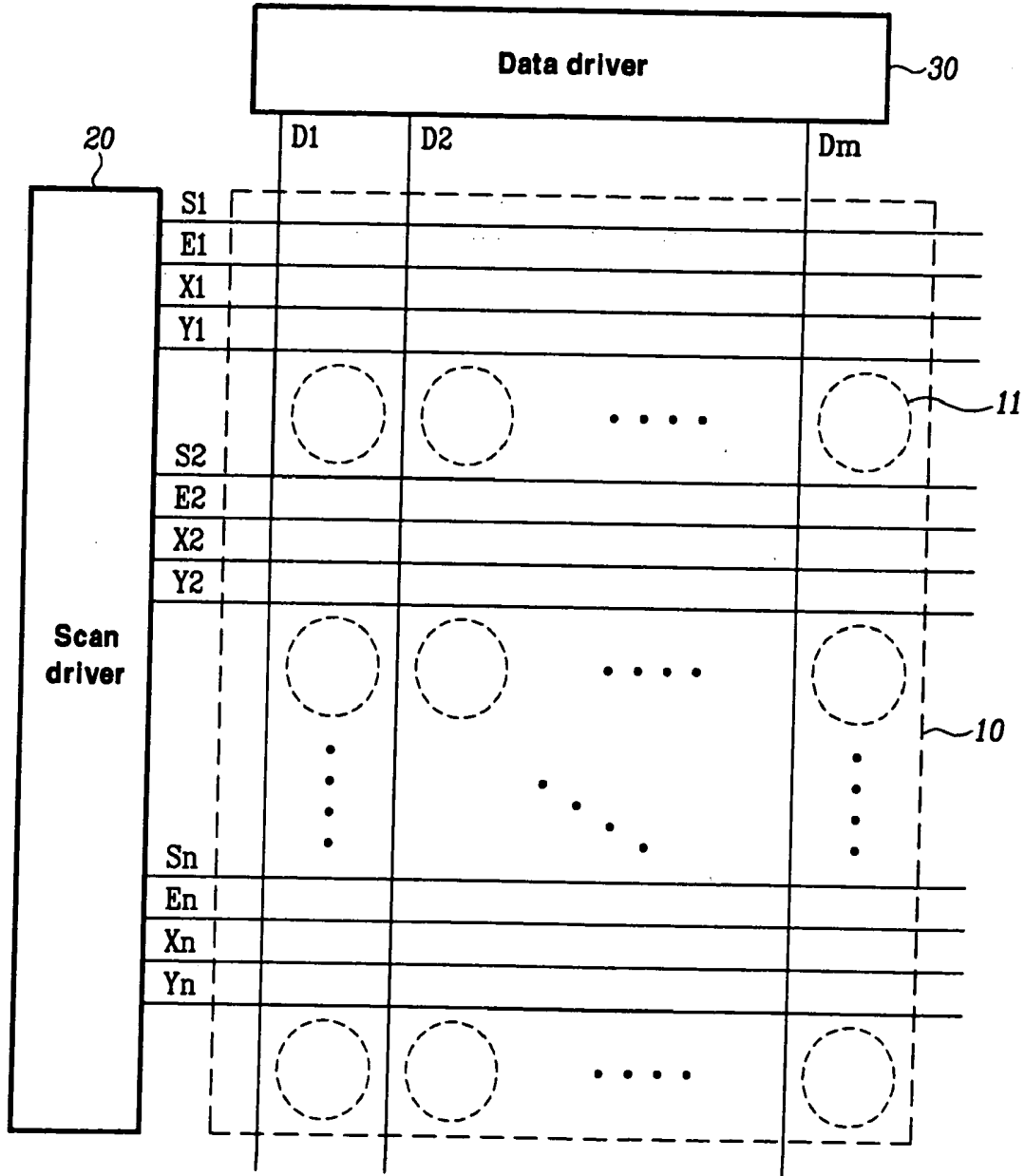

FIG.5

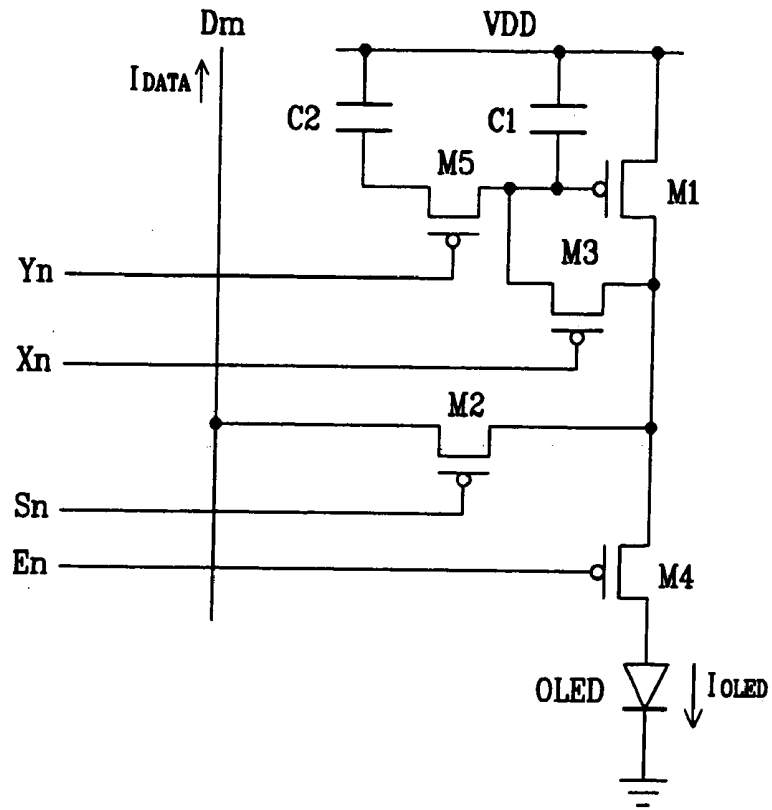

FIG.6

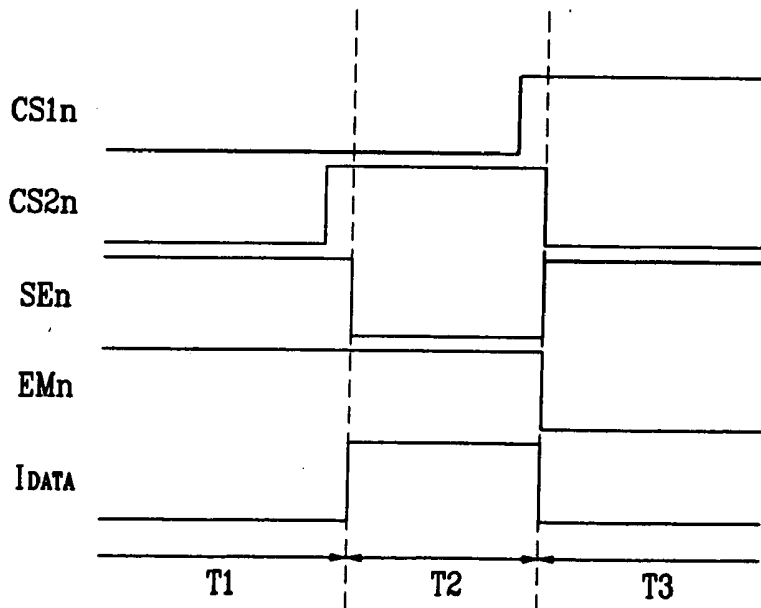

FIG.7

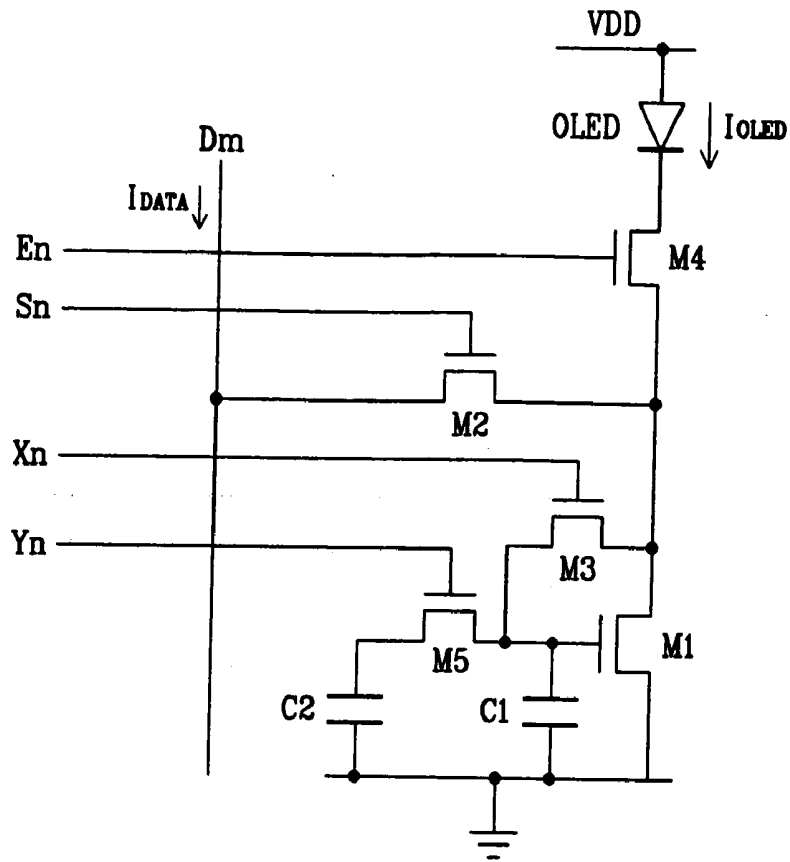

FIG.8

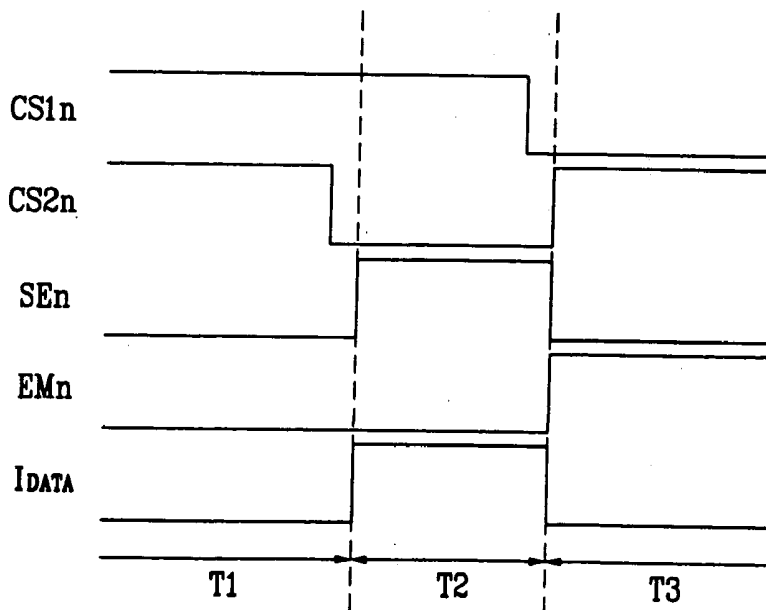

FIG.9

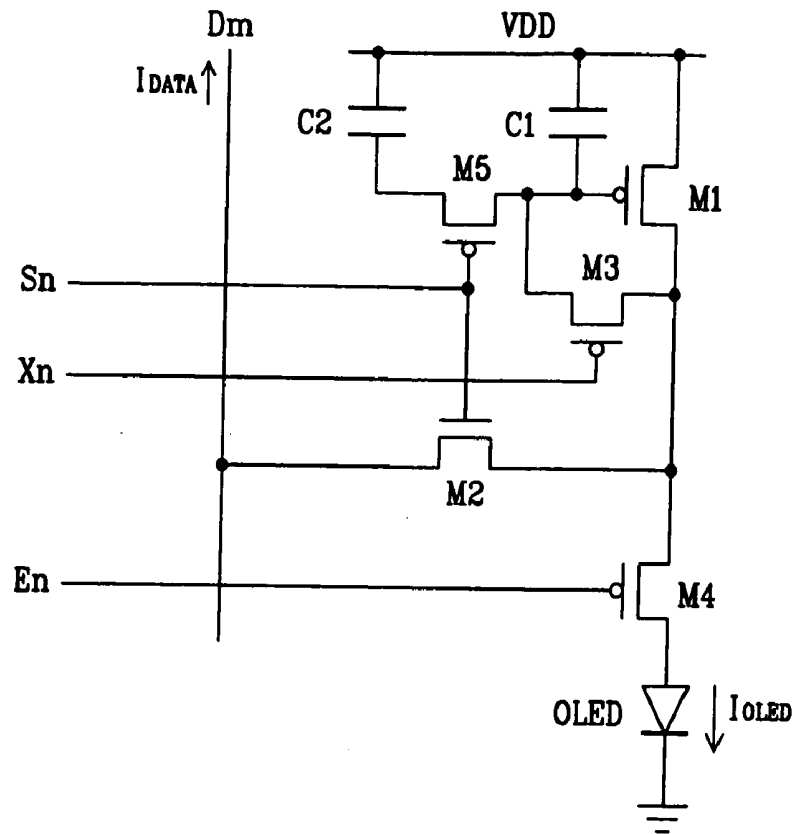

FIG.10

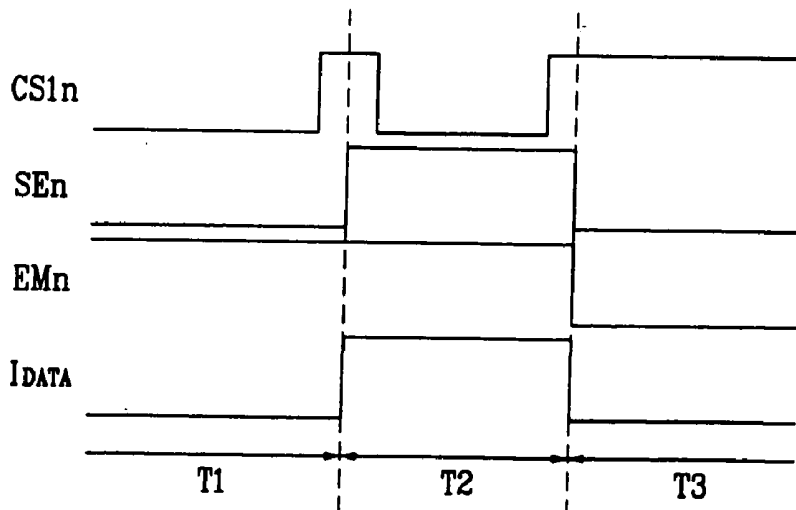

FIG.11

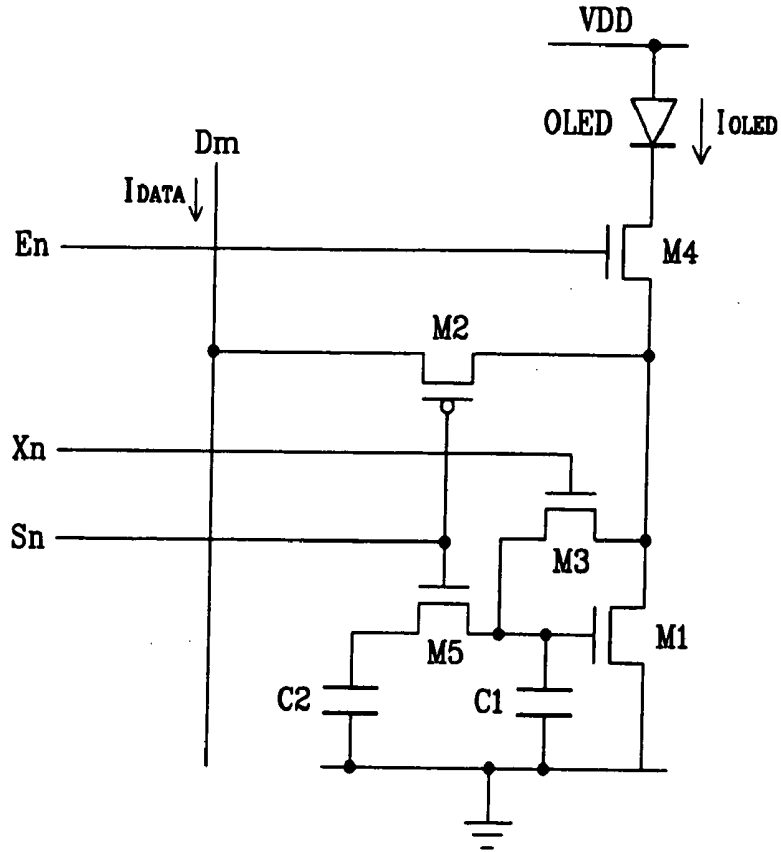

FIG.12

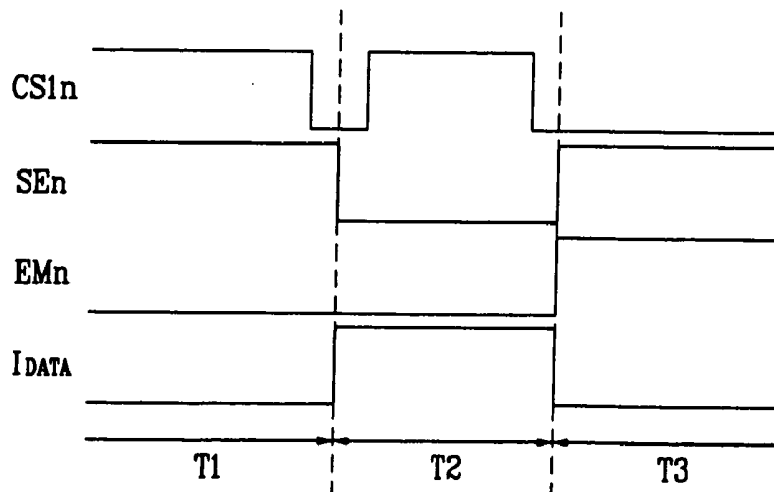

FIG.14

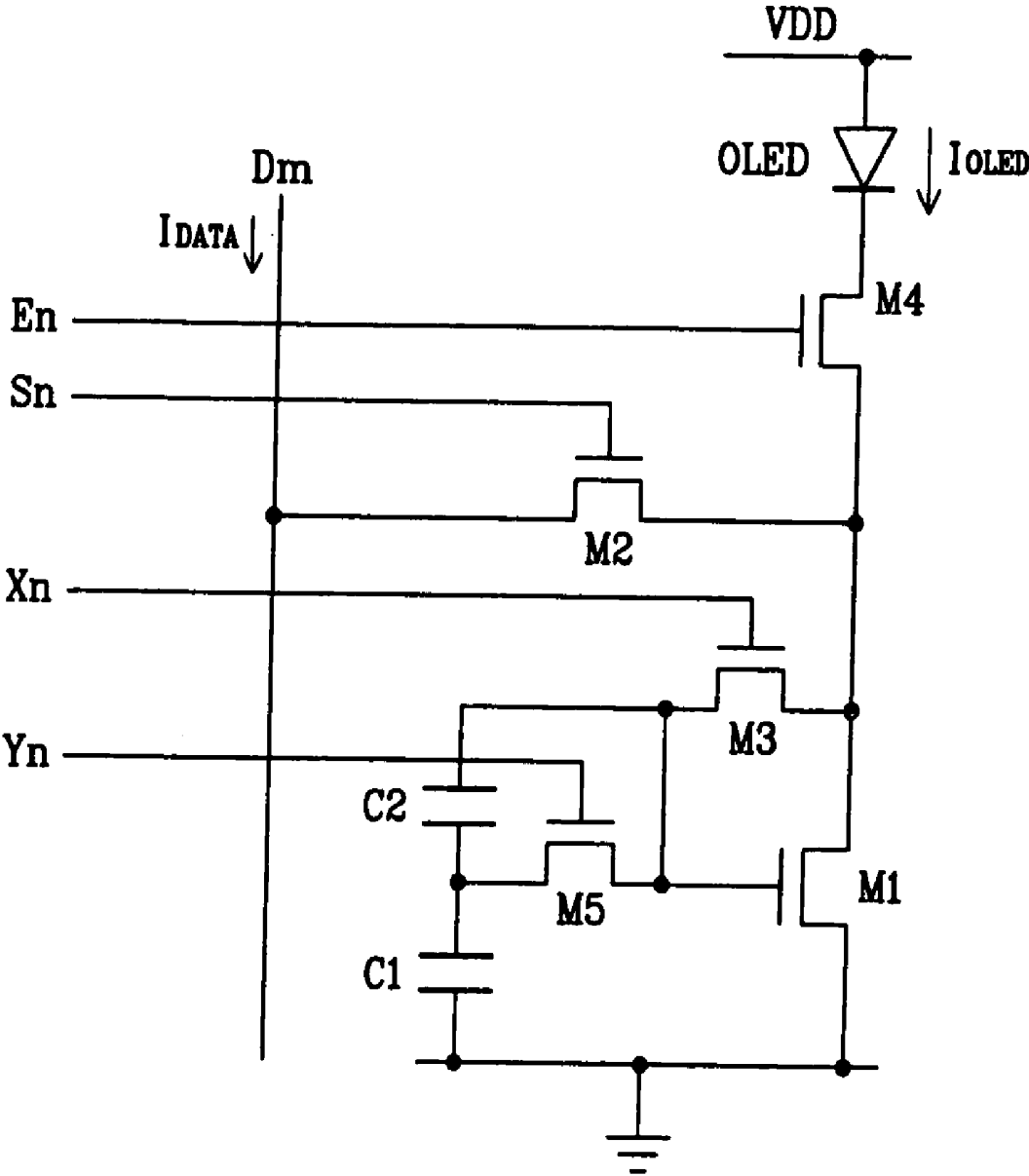

FIG.15

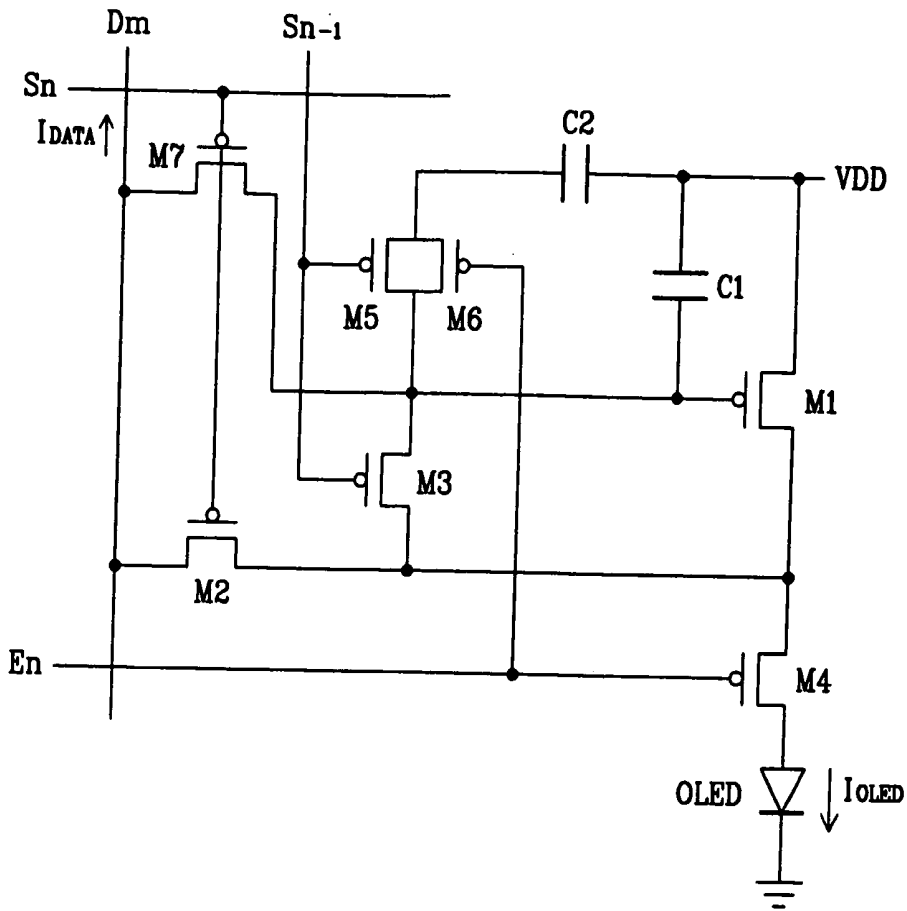
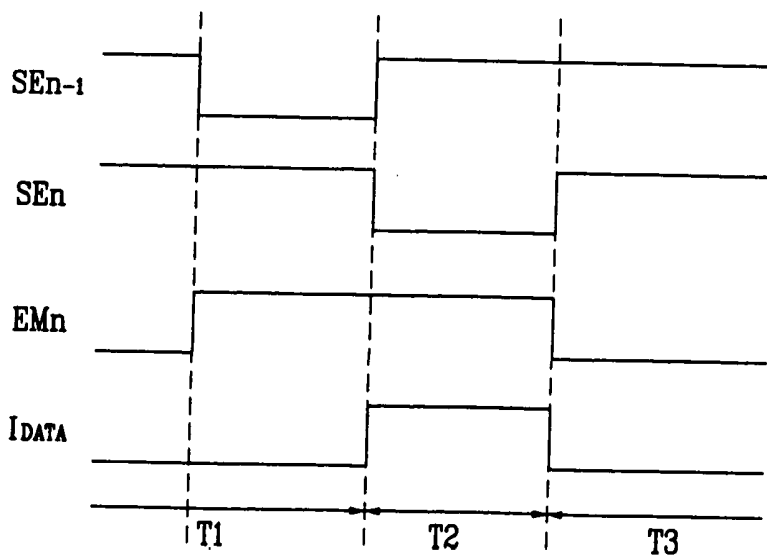

FIG.16



LIGHT EMITTING DISPLAY, DISPLAY PANEL, AND DRIVING METHOD THEREOF

CROSS-REFERENCE TO RELATED APPLICATION(S)

[0001] This application is a continuation of U.S. patent application Ser. No. 10/729,256 filed Dec. 4, 2003, which claims priority to and the benefit of Korea Patent Application No. 2003-20432 filed on Apr. 1, 2003 in the Korean Intellectual Property Office, the entire content of which is incorporated herein by reference.

BACKGROUND OF THE INVENTION

[0002] (a) Field of the Invention

[0003] The present invention relates to a light emitting display, a display panel, and a driving method thereof. More specifically, the present invention relates to an organic electroluminescent (EL) display.

[0004] (b) Description of the Related Art

[0005] In general, an organic EL display electrically excites a phosphorous organic compound to emit light, and it voltage- or current-drives N×M organic emitting cells to display images. As shown in FIG. 1, the organic emitting cell includes an anode of indium tin oxide (ITO), an organic thin film, and a cathode layer of metal. The organic thin film has a multi-layer structure including an emitting layer (EML), an electron transport layer (ETL), and a hole transport layer (HTL) for maintaining balance between electrons and holes and improving emitting efficiencies, and it further includes an electron injecting layer (EIL) and a hole injecting layer (HIL).

[0006] Methods for driving the organic emitting cells include the passive matrix method, and the active matrix method using thin film transistors (TFTs) or metal oxide semiconductor field effect transistors (MOSFETS). The passive matrix method forms cathodes and anodes to cross with each other, and selectively drives lines. The active matrix method connects a TFT and a capacitor with each ITO pixel electrode to thereby maintain a predetermined voltage according to capacitance. The active matrix method is classified as a voltage programming method or a current programming method according to signal forms supplied for maintaining a voltage at a capacitor.

[0007] Referring to FIGS. 2 and 3, conventional organic EL displays of the voltage programming and current programming methods will be described.

[0008] FIG. 2 shows a conventional voltage programming type pixel circuit for driving an organic EL element, representing one of N×M pixels. Referring to FIG. 2, transistor M1 is coupled to an organic EL element (referred to as an OLED hereinafter) to thus supply current for light emission. The current of transistor M1 is controlled by a data voltage applied through switching transistor M2. In this instance, capacitor C1 for maintaining the applied voltage for a predetermined period is coupled between a source and a gate of transistor M1. Scan line S_n is coupled to a gate of transistor M2, and data line Dm is coupled to a source thereof.

[0009] As to an operation of the above-configured pixel, when transistor M2 is turned on according to a select signal

applied to the gate of switching transistor M2, a data voltage from data line Dm is applied to the gate of transistor M1. Accordingly, current I_{OLED} flows to transistor M2 in correspondence to a voltage V_{GS} charged between the gate and the source by capacitor C1, and the OLED emits light in correspondence to current I_{OLED}.

[0010] In this instance, the current that flows to the OLED is given in Equation 1.

$$I_{OLED} = \frac{\beta}{2}(V_{GS} - V_{TH})^2 = \frac{\beta}{2}(V_{DD} - V_{DATA} - |V_{TH}|)^2 \quad \text{Equation 1}$$

[0011] where I_{OLED} is the current flowing to the OLED, V_{GS} is a voltage between the source and the gate of transistor M1, V_{TH} is a threshold voltage at transistor M1, and β is a constant.

[0012] As given in Equation 1, the current corresponding to the applied data voltage is supplied to the OLED, and the OLED gives light in correspondence to the supplied current, according to the pixel circuit of FIG. 2. In this instance, the applied data voltage has multi-stage values within a predetermined range so as to represent gray.

[0013] However, the conventional pixel circuit following the voltage programming method has a problem in that it is difficult to obtain high gray because of deviation of a threshold voltage V_{TH} of a TFT and deviations of electron mobility caused by non-uniformity of an assembly process. For example, in the case of driving a TFT of a pixel through 3 volts (3V), voltages are to be supplied to the gate of the TFT for each interval of 12 mV (=3V/256) so as to represent 8-bit (256) grays, and if the threshold voltage of the TFT caused by the non-uniformity of the assembly process deviates, it is difficult to represent high gray. Also, since the value β in Equation 1 changes because of the deviation of the mobility, it becomes even more difficult to represent the high gray.

[0014] On assuming that the current source for supplying the current to the pixel circuit is uniform over the whole panel, the pixel circuit of the current programming method can achieve uniform display features even though a driving transistor in each pixel has non-uniform voltage-current characteristics.

[0015] FIG. 3 shows a pixel circuit of a conventional current programming method for driving the OLED, representing one of N×M pixels. Referring to FIG. 3, transistor M1 is coupled to the OLED to supply the current for light emission, and the current of transistor M1 is controlled by the data current applied through transistor M2.

[0016] First, when transistors M2 and M3 are turned on because of the select signal from scan line S_n, transistor M1 becomes diode-connected, and the voltage matched with data current I_{DATA} from data line Dm is stored in capacitor C1. Next, the select signal from scan line S_n becomes high-level to turn on transistor M4. Then, the power is supplied from power supply voltage VDD, and the current matched with the voltage stored in capacitor C1 flows to the OLED to emit light. In this instance, the current flowing to the OLED is as follows.

$$I_{OLED} = \frac{\beta}{2} (V_{GS} - V_{TH})^2 = I_{DATA} \quad \text{Equation 2}$$

[0017] where V_{GS} is a voltage between the source and the gate of transistor M1, V_{TH} is a threshold voltage at transistor M1, and β is a constant.

[0018] As given in Equation 2, since current I_{OLED} flowing to the OLED is the same as data current I_{DATA} in the conventional current pixel circuit, uniform characteristics can be obtained when the programming current source is set to be uniform over the whole panel. However, since current I_{OLED} flowing to the OLED is a fine current, control over the pixel circuit by fine current I_{DATA} problematically requires much time to charge the data line. For example, assuming that the load capacitance of the data line is 30 pF, it requires several milliseconds of time to charge the load of the data line with the data current of several tens to hundreds of nA. This causes a problem that the charging time is not sufficient in consideration of the line time of several tens of microseconds.

SUMMARY OF THE INVENTION

[0019] In accordance with the present invention a light emitting display is provided for compensating for the threshold voltage of transistors or for electron mobility, and sufficiently charging the data line.

[0020] In one aspect of the present invention, a light emitting display is provided that includes a display panel on which a plurality of data lines for transmitting the data current that displays video signals, a plurality of scan lines for transmitting a select signal, and a plurality of pixel circuits formed at a plurality of pixels defined by the data lines and the scan lines are formed. The pixel circuit includes: a light emitting element for emitting light corresponding to the applied current; a first transistor, having first and second main electrodes and a control electrode, for supplying a driving current for the light emitting element; a first switch for diode-connecting the first transistor in response to a first control signal; a first storage unit for storing a first voltage corresponding to a threshold voltage of the first transistor in response to a second control signal; a second switch for transmitting a data signal from the data line in response to the select signal from the scan line; a second storage unit for storing a second voltage corresponding to the data current from the first switch; and a third switch for transmitting the driving current from the first transistor to the light emitting element in response to a third control signal. A third voltage determined by coupling of the first and second storage units respectively storing the first and second voltages is applied to the first transistor to supply the driving current to the light emitting element. The second control signal is enabled, the select signal is enabled, and the third control signal is then enabled in order. The pixel circuit further includes a fourth switch turned on in response to the second control signal, and coupled to a control electrode of the first transistor. The second storage unit is formed by a first capacitor coupled between the control electrode and the first main electrode of the first transistor. The first storage unit is formed by parallel coupling of a second capacitor coupled between the first main electrode of the first transis-

tor and a second end of the fourth switch, and the first capacitor. The second control signal is the select signal from the scan line, and the fourth switch responds in the disable interval of the select signal. The first control signal includes a select signal from the previous scan line and a select signal from the current scan line. The first switch includes a second transistor for diode-connecting the first transistor in response to the select signal from the previous scan line, and a third transistor for diode-connecting the first transistor in response to the select signal from the current scan line. The second control signal includes a select signal from the previous scan line, and the third control signal. The pixel circuit further includes a fifth switch coupled in parallel to the fourth switch. The fourth and fifth transistors are respectively turned on in response to the select signal from the previous scan line and the third control signal.

[0021] In another aspect of the present invention, a display panel of a light emitting display, on which a plurality of data lines for transmitting the data current that displays video signals, a plurality of scan lines for transmitting a select signal, and a plurality of pixel circuits formed at a plurality of pixels defined by the data lines and the scan lines are formed. The pixel circuit includes: a first transistor having a first main electrode coupled to a first power supplying a first voltage; a first switch coupled between a second main electrode of the first transistor and the data line, and being controlled by a first select signal from the scan line; a second switch controlled by a first control signal to diode-connect the first transistor; a third switch having a first end coupled to a control electrode of the first transistor, and being controlled by a second control signal; a fourth switch having a first end coupled to a second main electrode of the first transistor, and being controlled by a third control signal; a light emitting element, coupled between a second end of the fourth switch and a second power supplying a second voltage, for emitting light corresponding to the applied current; a first storage unit coupled between the control electrode and the first main electrode of the first transistor when the third switch is turned on; and a second storage unit coupled between the control electrode and the first main electrode of the first transistor when the third switch is turned off.

[0022] In still another aspect of the present invention, a method is provided for driving a light emitting display including a pixel circuit including a switch for transmitting a data current from a data line in response to a select signal from a scan line, a transistor including first and second main electrodes and a control electrode for outputting the driving current in response to the data current, and a light emitting element for emitting light corresponding to the driving current from the transistor. A first voltage corresponding to a threshold voltage of the transistor is stored in a first storage unit formed between the control electrode and the first main electrode of the transistor. A second voltage corresponding to the data current from the switch is stored in a second storage unit formed between the control electrode and the first main electrode of the transistor. The first and second storage units are coupled to establish the voltage between the control electrode and the first main electrode of the transistor as a third voltage. The driving current is transmitted from the transistor to the light emitting display, wherein the driving current from the transistor is determined corresponding to the third voltage.

[0023] In still yet another aspect of the present invention, a method is provided for driving a light emitting display including a pixel circuit including a switch for transmitting a data current from a data line in response to a select signal from a scan line, a transistor including first and second main electrodes and a control electrode for outputting the driving current in response to the data current, and a light emitting element for emitting light corresponding to the driving current from the transistor. The transistor is diode-connected in response to a first control signal. A first storage unit is coupled between the control electrode and the first main electrode of the transistor in response to a first level of a second control signal to store a first voltage corresponding to a threshold voltage of the transistor in the first storage unit. The transistor is diode-connected by the first control signal. A second storage unit is coupled between the control electrode and the first main electrode of the transistor in response to a second level of the second control signal. A second voltage corresponding to the data current is stored in the second storage unit in response to the first select signal. The first and second storage units are coupled in response to the first level of the second control signal to establish the voltage between the control electrode and the first main electrode of the transistor as a third voltage. A driving current is provided corresponding to the third voltage to the transistor. The driving current is provided to the light emitting element in response to a third control signal.

[0024] In a still further another aspect of the present invention, in a method for transmitting a data current showing video signals to a transistor in response to a first select signal to drive a light emitting element, a method for driving a light emitting display is provided. First and second control signals are established respectively applied to first and second switches as an enable level to store a first voltage corresponding to a threshold voltage of the transistor. A third control signal is established applied to a third switch as a disable level to electrically intercept the transistor and the light emitting element. The first select signal is established as a disable level to intercept the data current. The first select signal is established as an enable level to supply the data current. The first and second control signals are respectively established as enable and disable levels to store a second voltage corresponding to the data current. The first select signal is established as a disable level to intercept the data current. The first and second control signals are respectively established as disable and enable levels to apply a third voltage to a main electrode and a gate electrode of the transistor. The third control signal is established as an enable level to transmit the current from the transistor to the light emitting element, wherein the third voltage is determined by the first and second voltages.

BRIEF DESCRIPTION OF THE DRAWINGS

[0025] FIG. 1 shows a concept diagram of an OLED.

[0026] FIG. 2 shows an equivalent circuit of a conventional pixel circuit following the voltage programming method.

[0027] FIG. 3 shows an equivalent circuit of a conventional pixel circuit following the current programming method.

[0028] FIG. 4 shows a brief plane diagram of an organic EL display according to an embodiment of the present invention,

[0029] FIGS. 5, 7, 9, 11, 13, 14, and 15 respectively show an equivalent circuit of a pixel circuit according to first through seventh embodiments of the present invention.

[0030] FIGS. 6, 8, 10, 12, and 16 respectively show a driving waveform for driving the pixel circuit of FIGS. 5, 7, 9, 11, and 15.

DETAILED DESCRIPTION OF THE INVENTION

[0031] An organic EL display, a corresponding pixel circuit, and a driving method thereof will be described in detail with reference to drawings.

[0032] First, referring to FIG. 4, the organic EL display will be described. FIG. 4 shows a brief ground plan of the OLED.

[0033] As shown, the organic EL display includes organic EL display panel 10, scan driver 20, and data driver 30.

[0034] Organic EL display panel 10 includes a plurality of data lines D_1 through D_m in the row direction, a plurality of scan lines S_1 through S_n , E_1 through E_n , X_1 through X_n , and Y_1 through Y_n , and a plurality of pixel circuits 11. Data lines D_1 through D_m transmit data signals that represent video signals to pixel circuit 11, and scan lines S_1 through S_n transmit select signals to pixel circuit 11. Pixel circuit 11 is formed at a pixel region defined by two adjacent data lines D_1 through D_m and two adjacent scan lines S_1 through S_n . Also, scan lines E_1 through E_n transmit emit signals for controlling emission of pixel circuits 11, and scan lines X_1 through X_n and Y_1 through Y_n respectively transmit control signals for controlling operation of pixel circuits 11.

[0035] Scan driver 20 sequentially applies respective select signals and emit signals to scan lines S_1 through S_n and E_1 through E_n , and control signals to scan lines X_1 through X_n and Y_1 through Y_n . Data driver 30 applies the data current that represents video signals to data lines D_1 through D_m .

[0036] Scan driver 20 and/or data driver 30 can be coupled to display panel 10, or can be installed, in a chip format, in a tape carrier package (TCP) coupled to display panel 10. The same can be attached to display panel 10, and installed, in a chip format, on a flexible printed circuit (FPC) or a film coupled to display panel 10, which is referred to as a chip on flexible (CoF) board, or chip on film method. Differing from this, scan driver 20 and/or data driver 30 can be installed on the glass substrate of the display panel, and further, the same can be substituted for the driving circuit formed in the same layers of the scan lines, the data lines, and TFTs on the glass substrate, or directly installed on the glass substrate, which is referred to as a chip on glass (CoG) method.

[0037] Referring to FIGS. 5 and 6, pixel-circuit 11 of the organic EL display according to the first embodiment of the present invention will now be described. FIG. 5 shows an equivalent circuit diagram of the pixel circuit according to the first embodiment, and FIG. 6 shows a driving waveform diagram for driving the pixel circuit of FIG. 5. In this instance, for ease of description, FIG. 5 shows a pixel circuit coupled to an m-th data line D_m and an n-th scan line S_n .

[0038] As shown in FIG. 5, pixel circuit 11 includes an OLED, PMOS transistors M1 through M5, and capacitors C1 and C2. The transistor is preferably a thin film transistor

having a gate electrode, a drain electrode, and a source electrode formed on the glass substrate as a control electrode and two main electrodes.

[0039] Transistor M1 has a source coupled to power supply voltage VDD, and a gate coupled to transistor M5, and transistor M3 is coupled between the gate and a drain of transistor M1. Transistor M1 outputs current I_{OLED} corresponding to a voltage V_{GS} at the gate and the source thereof. Transistor M3 diode-connects transistor M1 in response to a control signal CS1 from scan line X_n . Capacitor C1 is coupled between power supply voltage VDD and the gate of transistor M1, and capacitor C2 is coupled between power supply voltage VDD and a first end of transistor M5. Capacitors C1 and C2 operate as storage elements for storing the voltage between the gate and the source of the transistor. A second end of transistor M5 is coupled to the gate of transistor M1, and transistor M5 couples capacitors C1 and C2 in response to a control signal CS2_n from scan line Y_n .

[0040] Transistor M2 transmits data current I_{DATA} from transistor M1 to data line D_m in response to a select signal SE_n from scan line S_n . Transistor M4 coupled between the drain of transistor M1 and the OLED, transmits current I_{OLED} of transistor M1 to the OLED in response to an emit signal EM_n of scan line E_n . The OLED is coupled between transistor M4 and the reference voltage, and emits light corresponding to applied current I_{OLED} .

[0041] Referring to FIG. 6, an operation of the pixel circuit according to the first embodiment of the present invention will now be described in detail.

[0042] As shown, in interval T1, transistor M5 is turned on because of low-level control signal CS2_n, and capacitors C1 and C2 are coupled in parallel between the gate and the source of transistor M1. Transistor M3 is turned on because of low-level control signal CS1_n, transistor M1 is diode-connected, and the threshold voltage V_{TH} of transistor M1 is stored in capacitors C1 and C2 coupled in parallel because of diode-connected transistor M1. Transistor M4 is turned off because of high-level emit signal EM_n, and the current to the OLED is intercepted. That is, in interval T1, the threshold voltage V_{TH} of transistor M1 is sampled to capacitors C1 and C2.

[0043] In interval T2, control signal CS2_n becomes high level to turn off transistor M5, and select signal SE_n becomes low level to turn on transistor M2. Capacitor C2 is floated while charged with voltage, because of turned-off transistor M5. Data current I_{DATA} from transistor M1 flows to data line D_m because of turned-on transistor M2. Accordingly, the gate-source voltage V_{GS} (T2) at transistor M1 is determined corresponding to data current I_{DATA} , and the gate-source voltage V_{GS} (T2) is stored in capacitor C1. Since data current I_{DATA} flows from transistor M1, data current I_{DATA} can be expressed as Equation 3, and the gate-source voltage V_{GS} (T2) in interval T2 is given as Equation 4 derived from Equation 3. That is, the gate-source voltage corresponding to data current I_{DATA} is programmed to capacitor C1 of the pixel circuit in interval T2.

$$I_{DATA} = \frac{\beta}{2} (|V_{GS}(T2)| - |V_{TH}|)^2 \quad \text{Equation 3}$$

-continued

$$|V_{GS}(T2)| = \sqrt{\frac{2I_{DATA}}{\beta}} + |V_{TH}| \quad \text{Equation 4}$$

[0044] where β is a constant.

[0045] Next, in interval T3, transistors M3 and M2 are turned off in response to high-level control signal CS1 and select signal SE_n, and transistors M5 and M4 are turned on because of low-level control signal CS2_n and emit signal EM_n. When transistor M5 is turned on, the gate-source voltage V_{GS} (T3) at transistor M1 in interval T3 becomes Equation 5 because of coupling of capacitors C1 and C2.

$$|V_{GS}(T3)| = |V_{TH}| + \frac{C_1}{C_1 + C_2} (|V_{GS}(T2)| - |V_{TH}|) \quad \text{Equation 5}$$

[0046] where C1 and C2 are respectively the capacitance of capacitors C1 and C2.

[0047] Therefore, current I_{OLED} flowing to transistor M1 becomes as Equation 6, and current I_{OLED} is supplied to the OLED because of turned-on transistor M4, to thereby emit light. That is, in interval T3, the voltage is provided and the OLED emits light because of coupling of capacitors C1 and C2.

$$I_{OLED} = \frac{\beta}{2} \left\{ \frac{C_1}{C_1 + C_2} (|V_{GS}(T2)| - |V_{TH}|) \right\}^2 = \left(\frac{C_1}{C_1 + C_2} \right)^2 I_{DATA} \quad \text{Equation 6}$$

[0048] As expressed in Equation 6, since current I_{OLED} supplied to the OLED is determined with no relation to the threshold voltage V_{TH} of transistor M1 or the mobility, the deviation of the threshold voltage or the deviation of the mobility can be corrected. Also, current I_{OLED} supplied to the OLED is $C_1/(C_1+C_2)$ squared times smaller than the data current I_{DATA} . For example, if C2 is M times greater than C1 (C2=M×C1), the fine current flowing to the OLED can be controlled by data current I_{DATA} which is (M+1)² times greater than current I_{OLED} , thereby enabling representation of high gray. Further, since the large data current I_{DATA} is supplied to data lines D_1 through D_m , charging time for the data lines can be sufficiently obtained.

[0049] In the first embodiment, PMOS transistors are used for transistors M1 through M5. However, NMOS transistors can also be implemented, which will now be described referring to FIGS. 7 and 8.

[0050] FIG. 7 shows an equivalent circuit diagram of the pixel circuit according to a second embodiment of the present invention, and FIG. 8 shows a driving waveform diagram for driving the pixel circuit of FIG. 7.

[0051] The pixel circuit of FIG. 7 includes NMOS transistors M1 through M5, and their coupling structure is symmetric with the pixel circuit of FIG. 5. In detail, transistor M1 has a source coupled to the reference voltage, a gate coupled to transistor M5, and transistor M3 is coupled between the gate and a drain of transistor M1. Capacitor C1

is coupled between the reference voltage and the gate of transistor M1, and capacitor C2 is coupled between the reference voltage and a first end of transistor M5. A second end of transistor M5 is coupled to the gate of transistor M1, and control signals CS1_n and CS2_n from scan lines X_n and Y_n are respectively applied to the gates of transistors M3 and M5. Transistor M2 transmits data current I_{DATA} from data line D_m to transistor M1 in response to select signal SE_n from scan line S_n. Transistor M4 is coupled between the drain of transistor M1 and the OLED, and emit signal EM_n from scan line En is applied to the gate of transistor M4. The OLED is coupled between transistor M4 and power supply voltage VDD.

[0052] Since the pixel circuit of FIG. 7 includes NMOS transistors, the driving waveform for driving the pixel circuit of FIG. 7 has an inverse form of the driving waveform of FIG. 6, as shown in FIG. 8. Since the detailed operation of the pixel circuit according to the second embodiment of the present invention can be easily obtained from the description of the first embodiment and FIGS. 7 and 8, no further detailed description will be provided.

[0053] According to the first and second embodiments, since transistors M1 through M5 are the same type transistors, a process for forming TFTs on the glass substrate of display panel 10 can be easily executed.

[0054] Transistors M1 through M5 are PMOS or NMOS types in the first and second embodiments, but without being restricted to this, they can be realized using combination of PMOS and NMOS transistors, or other switches having similar functions.

[0055] Two control signals CS1_n and CS2_n are used to control the pixel circuit in the first and second embodiments, and in addition, the pixel circuit can be controlled using a single control signal, which will now be described with reference to FIGS. 9 through 12.

[0056] FIG. 9 shows an equivalent circuit diagram of the pixel circuit according to a third embodiment of the present invention, and FIG. 10 shows a driving waveform diagram for driving the pixel circuit of FIG. 9.

[0057] As shown in FIG. 9, the pixel circuit has the same configuration as the first embodiment except for transistors M2 and M5. Transistor M2 includes an NMOS transistor, and gates of transistors M2 and M5 are coupled in common to scan line S_n. That is, transistor M5 is driven by select signal SE_n from scan line S_n.

[0058] Referring to FIG. 10, in interval T1, transistors M3 and M5 are turned on because of low-level control signal CS1_n and select signal SE_n. Transistor M1 is diode-connected because of turned-on transistor M3, and the threshold voltage V_{TH} at transistor M1 is stored in capacitors C1 and C2. Also, transistor M4 is turned off because of high-level emit signal EM_n, and the current flow to the OLED is intercepted.

[0059] In interval T2, select signal SE_n becomes high level to turn transistor M2 on and transistor M5 off. Then, the voltage V_{GS} (T2) expressed in Equation 4 is charged in capacitor C1. In this instance, since the voltage charged in capacitor C2 can be changed when transistor M2 is turned on because of select signal SE_n, in order to prevent this, transistor M3 is turned off before transistor M2 is turned on,

and again, transistor M3 is turned on after transistor M2 is turned on. That is, control signal CS1_n is inverted to high level for a short time before select signal SE_n becomes high level.

[0060] Since other operations in the third embodiment of the present invention are matched with those of the first embodiment, no further corresponding description will be provided. According to the third embodiment, scan lines Y₁ through Y_n for supplying control signal CS2_n can be removed, thereby increasing the aperture ratio of the pixels.

[0061] In the third embodiment, transistors M1 and M3 through M5 are realized with PMOS transistors, and transistor M2 with an NMOS transistor, and further, the opposite realization of the transistors are possible, which will be described with reference to FIGS. 11 and 12.

[0062] FIG. 11 shows an equivalent circuit diagram of the pixel circuit according to a fourth embodiment of the present invention, and FIG. 12 shows a driving waveform diagram for driving the pixel circuit of FIG. 11.

[0063] As shown in FIG. 11, the pixel circuit realizes transistor M2 with a PMOS transistor, and transistors M1 and M3 through M5 with NMOS transistors, and their coupling structure is symmetric with that of the pixel circuit of FIG. 9. Also, as shown in FIG. 12, the driving waveform for driving the pixel circuit of FIG. 11 has an inverse form of that of FIG. 10. Since the coupling structure and the operation of the pixel circuit according to the fourth embodiment can be easily obtained from the description of the third embodiment, no detailed description will be provided.

[0064] In the first through fourth embodiments, capacitors C1 and C2 are coupled in parallel to power supply voltage VDD, and differing from this, capacitors C1 and C2 can be coupled in series to power supply voltage VDD, which will now be described referring to FIGS. 13 and 14.

[0065] FIG. 13 shows an equivalent circuit diagram of the pixel circuit according to a fifth embodiment of the present invention.

[0066] As shown, the pixel circuit has the same structure as that of the first embodiment except for the coupling states of capacitors C1 and C2, and transistor M5. In detail, capacitors C1 and C2 are coupled in series between power supply voltage VDD and transistor M3, and transistor M5 is coupled between the common node of capacitors C1 and C2 and the gate of transistor M1.

[0067] The pixel circuit according to the fifth embodiment is driven with the same driving waveform as that of the first embodiment, which will now be described referring to FIGS. 6 and 13.

[0068] In interval T1, transistor M3 is turned on because of low-level control signal CS1_n to diode-connect transistor M1. The threshold voltage V_{TH} of transistor M1 is stored in capacitor C1 because of diode-connected transistor M1, and the voltage at capacitor C2 becomes 0V. Also, transistor M4 is turned off because of high-level emit signal EM_n to intercept the current flow to the OLED.

[0069] In interval T2, control signal CS2_n becomes high level to turn off transistor M5, and select SE_n becomes low level to turn on transistor M2. Data current I_{DATA} flows from transistor M1 to data line D_m because of turned-on transistor

M2, and the gate-source voltage $V_{GS}(T^2)$ at transistor **M1** becomes as shown in Equation 4. Hence, the voltage V_{C1} at capacitor **C1** charging the threshold voltage V_{TH} becomes as shown in Equation 7 because of coupling of capacitors **C1** and **C2**.

$$V_{C1} = |V_{TH}| + \frac{C_2}{C_1 + C_2} (|V_{GS}(T2)| - |V_{TH}|) \quad \text{Equation 7}$$

[0070] Next, in interval **T3**, transistors **M3** and **M2** are turned off in response to high-level control signal $CS1_n$ and select signal SE_n , and transistors **M5** and **M4** are turned on because of low-level control signal $CS2_n$ and emit signal EM_n . When transistor **M3** is turned off, and transistor **M5** is turned on, the voltage V_{C1} at capacitor **C1** becomes the gate-source voltage $V_{GS}(T3)$ of transistor **M1**. Therefore, current I_{OLED} flowing from transistor **M1** becomes as shown in Equation 8, and current I_{OLED} is supplied to the OLED according to transistor **M4** thereby emitting light.

$$I_{OLED} = \frac{\beta}{2} \left\{ \frac{C_2}{C_1 + C_2} (|V_{GS}(T2)| - |V_{TH}|) \right\}^2 = \left(\frac{C_2}{C_1 + C_2} \right)^2 I_{DATA} \quad \text{Equation 8}$$

[0071] In the like manner of the first embodiment, current I_{OLED} supplied to the OLED is determined with no relation to the threshold voltage V_{TH} of transistor **M1** or the mobility. Also, since the fine current flowing to the OLED using data current I_{DATA} that is $(C1+C2)/C2$ squared times current I_{OLED} can be controlled, high gray can be represented. By supplying large data current I_{DATA} to data lines D_1 through D_M , sufficient charging time of the data lines can be obtained.

[0072] Transistors **M1** through **M5** are realized with PMOS transistors in the fifth embodiment, and they can also be realized with NMOS transistors, which will now be described with reference to **FIG. 14**.

[0073] **FIG. 14** shows an equivalent circuit diagram of the pixel circuit according to a sixth embodiment of the present invention.

[0074] As shown, the pixel circuit realizes transistors **M1** through **M5** with NMOS transistors, and their coupling structure is symmetric with that of the pixel circuit of **FIG. 13**. The driving waveform for driving the pixel circuit of **FIG. 14** has an inverse driving waveform of the pixel circuit of **FIG. 14**, and it is the same driving waveform as that of **FIG. 8**. Since the coupling structure and the operation of the pixel circuit according to the sixth embodiment can be easily derived from the description of the fifth embodiment, no further detailed description will be provided.

[0075] Two or one control signal is used to control the pixel circuit in the first through sixth embodiments, and differing from this, the pixel circuit can be controlled by using a select signal of a previous scan line without using the control signal, which will now be described in detail with reference to **FIGS. 15 and 16**.

[0076] **FIG. 15** shows an equivalent circuit diagram of the pixel circuit according to a seventh embodiment of the

present invention, and **FIG. 16** shows a driving waveform diagram for driving the pixel circuit of **FIG. 15**.

[0077] As shown in **FIG. 15**, the pixel circuit has the same structure as that of the first embodiment except for transistors **M3**, **M5**, **M6**, and **M7**. In detail, transistor **M3** diode-connects transistor **M1** in response to select signal SE_{n-1} from previous scan line S_{n-1} , and transistor **M7** diode-connects transistor **M1** in response to select signal SE_n from current scan line S_n . Transistor **M7** is coupled between data line D_m and the gate of transistor **M1** in **FIG. 15**, and it can also be coupled between the gate and the drain of transistor **M1**. Transistors **M5** and **M6** are coupled in parallel between capacitor **C2** and the gate of transistor **M1**. Transistor **M5** responds to select signal SE_{n-1} from previous scan line S_{n-1} , and transistor **M6** responds to emit signal EM_n from scan line E_n .

[0078] Next, the operation of the pixel circuit of **FIG. 15** will be described referring to **FIG. 16**.

[0079] As shown, in interval **T1**, transistors **M3** and **M5** are turned on because of low-level select signal SE_{n-1} . Capacitors **C1** and **C2** are coupled in parallel between the gate and the source of transistor **M1** because of turned-on transistor **M5**. Transistor **M1** is diode-connected because of turned-on transistor **M3** to store the threshold voltage V_{TH} of transistor **M1** in capacitors **C1** and **C2** coupled in parallel. Transistors **M2**, **M7**, **M4**, and **M6** are turned off because of high-level select signal SE_n and emit signal EM_n .

[0080] In interval **T2**, select signal SE_{n-1} becomes high level to turn off transistor **M3**, and transistor **M7** is turned on because of low-level select signal SE_n to diode-connect transistor **M1** and maintain the diode-connected state of transistor **M1**. Transistor **M5** is turned off because of select signal SE_{n-1} to have capacitor **C2** be floated while storing the voltage. Transistor **M2** is turned on because of select signal SE_n to make data current I_{DATA} from transistor **M1** flow to data line D_m . The gate-source voltage $V_{GS}(T2)$ of transistor **M1** is determined corresponding to data current I_{DATA} , and the gate-source voltage $V_{GS}(T2)$ is given as Equation 4 in the same manner of the first embodiment.

[0081] Next, in interval **T3**, select signal SE_n becomes high level to turn off transistors **M2** and **M7**, and transistors **M4** and **M6** are turned on because of low-level emit signal EM_n . When transistor **M6** is turned on, the gate-source voltage $V_{GS}(T3)$ of transistor **M1** is given as Equation 5 because of coupling of capacitors **C1** and **C2** in the like manner of the first embodiment. Therefore, current I_{OLED} shown in Equation 6 is supplied to the OLED because of turned-on transistor **M4** to emit light.

[0082] The two control signals $CS1_n$ and $CS2_n$ are removed in the seventh embodiment, and differing from this, one of control signals $CS1_n$ and $CS2_n$ can be removed. In detail, in the case of additionally using control signal $CS1_n$ in the seventh embodiment, transistor **M7** is removed from the pixel circuit of **FIG. 15**, and transistor **M3** is driven by not select signal SE_{n-1} but by control signal $CS1$. In the case of additionally using control signal $CS2_n$ in the seventh embodiment, transistor **M6** is removed from the pixel circuit of **FIG. 15**, and transistor **M5** is not driven by the select signal SE_{n-1} and emit signal EM_n but by control signal $CS2_n$. Accordingly, the number of wires increases compared to **FIG. 15**, but the number of transistors can be reduced.

[0083] In the above, PMOS and/or NMOS transistors are used to realize a pixel circuit in the first through seventh embodiments, and without being restricted to this, the pixel circuit can be realized by PMOS transistors, NMOS transistors, or a combination of PMOS and NMOS transistors, and by other switches having similar functions.

[0084] Accordingly, since the current flowing to the OLED can be controlled using the large data current, the data line can be sufficiently charged during a single line time frame. Also, the deviation of the threshold voltage of the transistor or the deviation of the mobility is corrected, and a light emission display with high resolution and a wide screen can be realized.

[0085] While this invention has been described in connection with what is presently considered to be practical embodiments, it is to be understood that the invention is not limited to the disclosed embodiments, but, on the contrary, is intended to cover various modifications and equivalent arrangements included within the spirit and scope of the appended claims.

What is claimed is:

1. A display comprising:
 - a data line for transmitting a data current;
 - a scan line for applying a select signal;
 - a switch coupled to the data line and turned on in response to the select signal from the scan line in a first period such that the data current flows through the switch;
 - a transistor having a first electrode; a second electrode and a control electrode, and for providing a current corresponding to a voltage between the first electrode and the control electrode through the second electrode;
 - a first capacitor coupled between the first electrode and the control electrode of the transistor, for storing a voltage corresponding to a threshold voltage of the transistor in a second period before the first period, and for storing a voltage corresponding to the data current flowing through the switch in the first period;
 - a second capacitor electrically coupled to the first capacitor in parallel in the second period and a third period after the first period, and having one end electrically blocked from the first capacitor in the first period; and
 - an emitting element for emitting light in response to the current provided through the second electrode of the transistor in the third period.
2. The display of claim 1, wherein the second electrode of the transistor is electrically coupled to the control electrode of the transistor in the first and second periods.
3. The display of claim 2, wherein the second electrode and the control electrode of the transistor are electrically coupled to the data line in the first period.
4. The display of claim 2, wherein in the third period, the first electrode of the transistor is electrically coupled to a first voltage source, the second electrode of the transistor is electrically coupled to a first electrode of the emitting element, and a second electrode of the emitting element is electrically coupled to a second voltage source.
5. The display of claim 4, wherein the second electrode of the transistor is electrically blocked from the second voltage source in the first and second periods.

6. The display of claim 4, wherein the transistor is a PMOS transistor, a voltage of the first voltage source is higher than a voltage of the second voltage source, the first electrode of the emitting element is an anode electrode, and the second electrode of the emitting element is a cathode electrode.

7. The display of claim 4, wherein the transistor is an NMOS transistor, a voltage of the first voltage source is lower than a voltage of the second voltage source, the first electrode of the emitting element is a cathode electrode, and the second electrode of the emitting element is an anode electrode.

8. The display of claim 1, wherein the emitting element emits light by an emission of an organic material.

9. A display comprising:

- a data line for transmitting a data current;
- a scan line for applying a select signal;
- a first switch coupled to the data line and turned on in response to the select signal from the scan line in a first period such that the data current flows through the first switch;
- a transistor having a first electrode, a second electrode and a control electrode, and for providing a current corresponding to a voltage between the first electrode and the control electrode through the second electrode;
- at least one second switch for electrically coupling the second electrode of the transistor to the control electrode of the transistor in the first period and a second period before the first period;
- a first capacitor coupled between the first electrode of the transistor and the control electrode of the transistor, and for storing a voltage corresponding to the data current flowing through the first switch in the first period;
- a second capacitor electrically coupled to the first capacitor in parallel in the second period and a third period after the first period, and having one end electrically blocked from the first capacitor in the first period; and
- an emitting element for emitting light in response to the current provided through the second electrode of the transistor in the third period.

10. The display of claim 9, wherein the at least one second switch includes

- a third switch coupled between the control electrode of the transistor and the second electrode of the transistor, and turned on in the second period; and
- a fourth switch coupled between the control electrode of the transistor and the data line, and turned on in the first period.

11. The display of claim 9, wherein in the third period, the first electrode of the transistor is electrically coupled to a first voltage source, the second electrode of the transistor is electrically coupled to a first electrode of the emitting element, and a second electrode of the emitting element is electrically coupled to a second voltage source.

12. The display of claim 11, wherein the second electrode of the transistor is electrically blocked from the second voltage source in the first and second periods.

13. The display of claim 11, wherein the transistor is a PMOS transistor, a voltage of the first voltage source is

higher than a voltage of the second voltage source, the first electrode of the emitting element is an anode electrode, and the second electrode of the emitting element is a cathode electrode.

14. The display of claim 11, wherein the transistor is an NMOS transistor, a voltage of the first voltage source is lower than a voltage of the second voltage source, the first electrode of the emitting element is a cathode electrode, and the second electrode of the emitting element is an anode electrode.

15. The display of claim 9, wherein the emitting element emits light by an emission of an organic material.

16. A display comprising:

a data line for transmitting a data current;

a scan line for applying a select signal;

a switch coupled to the data line and turned on in response to the select signal from the scan line in a first period such that the data current flows through the switch;

a transistor having a first electrode, a second electrode and a control electrode, and for providing a current corresponding to a voltage between the first electrode and the control electrode through the second electrode;

a first capacitor electrically coupled between the first electrode and the control electrode of the transistor in a second period before the first period and a third period after the first period, and for storing a voltage corresponding to a threshold voltage of the transistor in the second period;

a second capacitor, the first capacitor and the second capacitor coupled in series between the first electrode of the transistor and the control electrode of the transistor, the second capacitor being for storing a voltage corresponding to the data current flowing through the switch in the first period; and

an emitting element for emitting light in response to the current provided through the second electrode of the transistor in the third period.

17. The display of claim 16, wherein the second electrode of the transistor is electrically coupled to the control electrode of the transistor in the first and second periods.

18. The display of claim 17, wherein the second electrode and the control electrode of the transistor are electrically coupled to the data line in the first period.

19. The display of claim 17, wherein in the third period, the first electrode of the transistor is electrically coupled to a first voltage source, the second electrode of the transistor is electrically coupled to a first electrode of the emitting element, and a second electrode of the emitting element is electrically coupled to a second voltage source.

20. The display of claim 19, wherein the second electrode of the transistor is electrically blocked from the second voltage source in the first and second periods.

21. The display of claim 19, wherein the transistor is a PMOS transistor, a voltage of the first voltage source is higher than a voltage of the second voltage source, the first electrode of the emitting element is an anode electrode, and the second electrode of the emitting element is a cathode electrode.

22. The display of claim 19, wherein the transistor is an NMOS transistor, a voltage of the first voltage source is

lower than a voltage of the second voltage source, the first electrode of the emitting element is a cathode electrode, and the second electrode of the emitting element is an anode electrode.

23. The display of claim 16, wherein the emitting element emits light by an emission of an organic material.

24. A display comprising:

a data line for transmitting a data current;

a scan line for applying a select signal;

a first switch coupled to the data line and turned on in response to the select signal from the scan line in a first period such that the data current flows through the first switch;

a transistor having a first electrode, a second electrode and a control electrode, and for providing a current corresponding to a voltage between the first electrode and the control electrode through the second electrode;

at least one second switch for electrically coupling the second electrode of the transistor to the control electrode of the transistor in the first period and a second period before the first period;

a first capacitor having a first electrode coupled to the first electrode of the transistor, and a second electrode electrically coupled to the control electrode of the transistor in the second period and a third period after the first period;

a second capacitor electrically coupled between the second electrode of the first capacitor and the control electrode of the transistor in the first period, the first and second capacitors being for storing a voltage corresponding to the data current flowing through the first switch in the first period; and

an emitting element for emitting light in response to the current provided through the second electrode of the transistor in the third period.

25. The display of claim 24, wherein in the third period, the first electrode of the transistor is electrically coupled to a first voltage source, the second electrode of the transistor is electrically coupled to a first electrode of the emitting element, and a second electrode of the emitting element is electrically coupled to a second voltage source.

26. The display of claim 25, wherein the second electrode of the transistor is electrically blocked from the first electrode of the emitting element in the first and second periods.

27. The display of claim 25, wherein the transistor is a PMOS transistor, a voltage of the first voltage source is higher than a voltage of the second voltage source, the first electrode of the emitting element is an anode electrode, and the second electrode of the emitting element is a cathode electrode.

28. The display of claim 25, wherein the transistor is an NMOS transistor, a voltage of the first voltage source is lower than a voltage of the second voltage source, the first electrode of the emitting element is a cathode electrode, and the second electrode of the emitting element is an anode electrode.

29. The display of claim 24, wherein the emitting element emits light by an emission of an organic material.

专利名称(译)	发光显示器，显示面板及其驱动方法		
公开(公告)号	US20050206593A1	公开(公告)日	2005-09-22
申请号	US11/140013	申请日	2005-05-27
申请(专利权)人(译)	三星SDI CO. , LTD.		
当前申请(专利权)人(译)	三星DISPLAY CO. , LTD.		
[标]发明人	KWON OH KYONG		
发明人	KWON, OH-KYONG		
IPC分类号	H01L51/50 G09G3/14 G09G3/20 G09G3/30 G09G3/32 G09G3/36 G11C11/00 H05B33/00 H05B33/14		
CPC分类号	G09G3/325 G09G2300/0852 G09G2300/0861 G09G2320/0233 G09G2310/0262 G09G2320/0223 G09G2310/0251		
优先权	1020030020432 2003-04-01 KR		
其他公开文献	US7573441		
外部链接	Espacenet USPTO		

摘要(译)

一种发光显示器，用于补偿晶体管的阈值电压或移动性并对数据线完全充电。晶体管 and 第一至第三开关形成在有机EL显示器的像素电路上。晶体管提供用于发射有机EL元件(OLED)的驱动电流。第一开关二极管连接晶体管。第一存储单元存储对应于晶体管的阈值电压的第一电压。第二开关响应于选择信号发送数据电流。第二存储单元存储对应于数据电流的第二电压。第三开关将驱动电流传输到OLED。通过第一和第二存储单元的耦合确定的第三电压被施加到晶体管以将驱动电流提供给OLED。

